

HORIZONTAL AXIS PEELER CENTRIFUGES TYPE EH

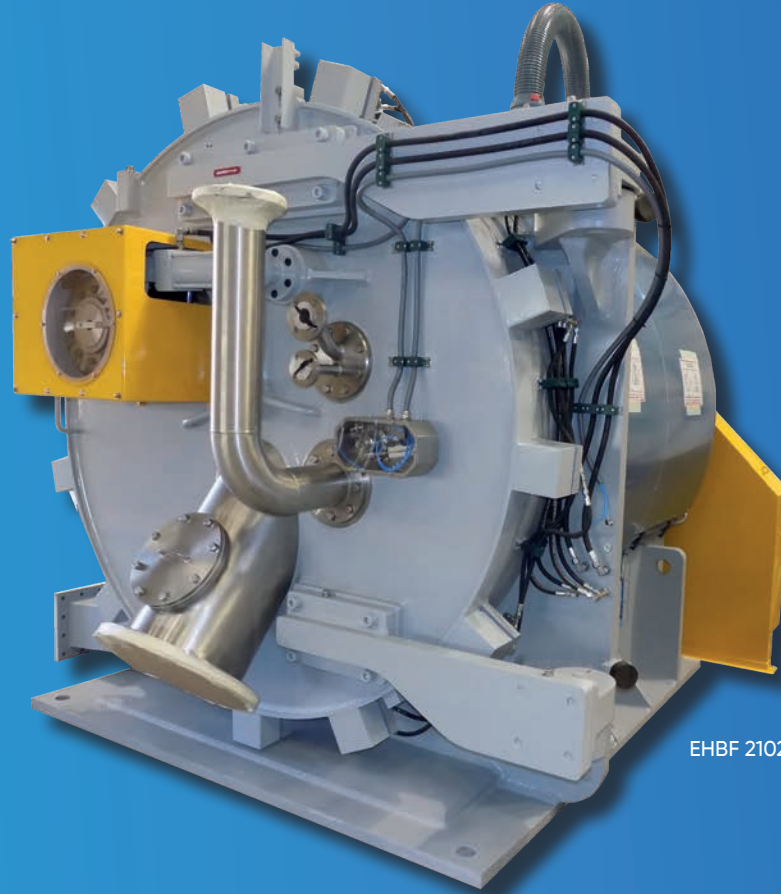

EHB 2102 J DCV

KEY FEATURES OF EH TYPE CENTRIFUGES



PRODUCTIVITY

- Ideal for mono product applications.
- Large diameter baskets with great useful volumes.
- Optimized cycle times (in some cases all cycle steps can be performed at high speed).



EFFICIENCY

- Due to the high centrifugal forces generated, these centrifuges can achieve maximum cake dryness.



RELIABILITY

- Required or integrated significant inertia mass.
- Outer casing design and assembly principle with fixed frame.
- Excellent stability and superior mechanical performance.

GENERAL DESIGN OF EH TYPE CENTRIFUGES

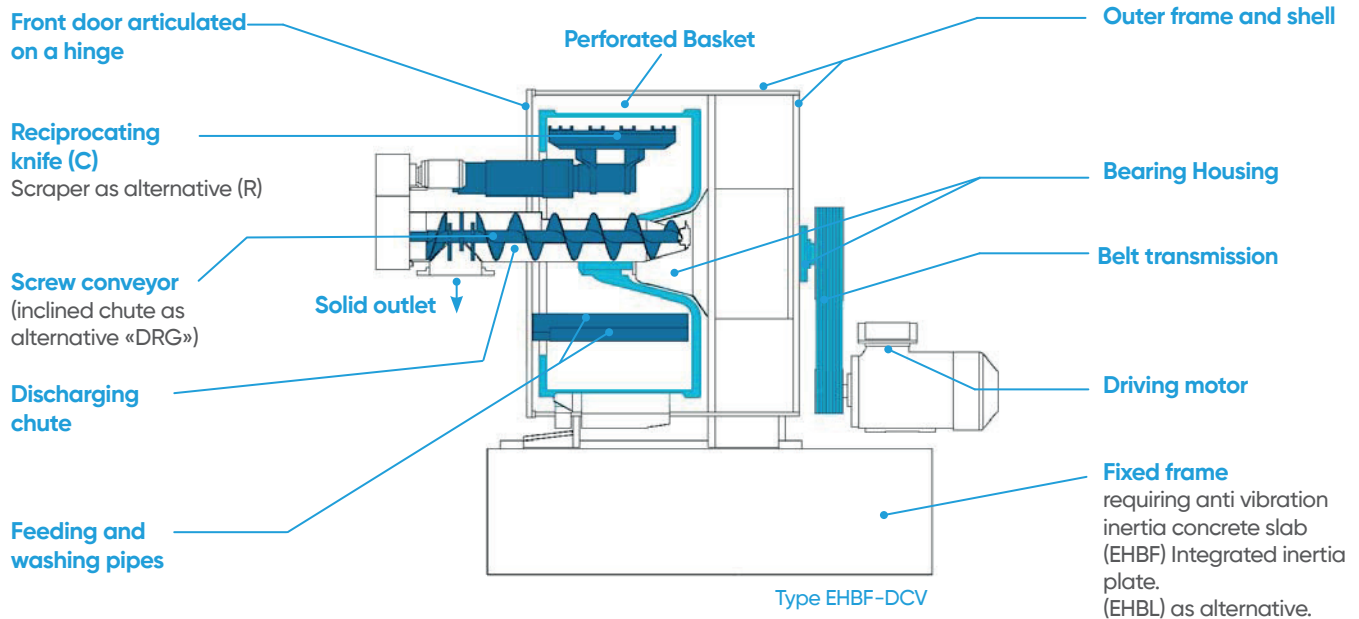

TECHNICAL CHARACTERISTICS OF EH CENTRIFUGES

TYPE EH	Basket						
	ø mm	Dept mm	Useful volume L	Maximum load kg	Filtration area m ²	Maximum speed rpm	Centrifugal force "G"
1322	1320	720	440	550	3	1235	1130
1662	1660	950	890	1110	5	1000	930
1762	1760	980	1040	1300	5,4	950	890
2102	2100	980	1500	1900	6,5	850	850
2102 J	2100	1120	1730	2100	7,4	850	850

Smaller capacity models: see our C8 and C4 leaflets.



Additional and optional equipment

- Cake washing pipe.
- Cake detector.
- Residual heel removal device.
 - Overflow liquid discharge.
 - Skimmer pipe.
- Various materials of construction (stainless steels, alloys...) or coatings, (HA LAR, rubber, ...) and gasket materials.
- Tight or explosion-proof (ATEX in the EC) electrical equipment ATEX compliance.
- Vapor tightness for operation under inert gas blanketing.
- Inerting Control Systems and hydraulic siphon.

HEADQUARTERS

ROUSSELET ROBATEL
45 Avenue Rhin et Danube
Parc d'activité économique de Marenton
07104 ANNONAY - FRANCE
Tel.: +33 (0)4 75 69 22 11
E-mail: info@rousselet-robotel.com

UK

Rousselet UK Ltd
Parkside House, 17 East Parade
HARROGATE
NORTH YORKSHIRE HG1 5LF
Tel: + 44 (0)1 423 530 093
E-mail: info@rousselet-robotel.com

DEUTSCHLAND

ARRGOS GmbH
Max-Eyth-Str. 1
D-71691 Freiberg a.N.
Tel: +49(0)7 7229 20
Fax: +0)173 757 6226
Email: nicolas.kiehl@arrgos.de

USA

Robotel Inc.
703 West Housatonic Street
PITTSFIELD
MA 01201
Tel: + 1 413 499 4818
E-mail: sales@rr-centrifuge.com